

*Original Research*

# Identification and Control Method of Temperature and Pressure Control System in Methane Isotope Measurement System

**Liu Xu<sup>1,2,3</sup>, Zhang Zhirong<sup>2,3,4,5\*</sup>, Sun Pengshuai<sup>2,4#</sup>, Wang Yanchun<sup>1</sup>,  
Zhang Lewen<sup>2,3</sup>, Pang Tao<sup>2,4</sup>, Xia Hua<sup>2,4</sup>, Wu Bian<sup>2,4</sup>**

<sup>1</sup>School of Electronic and Electrical Engineering, Bengbu University, Bengbu 233030, China

<sup>2</sup>Anhui Provincial Key Laboratory of Photonic Devices and Material, Anhui Institute of Optics and Fine Mechanics, Hefei Institutes of Physical Science, Chinese Academy of Science, Hefei 230031, China

<sup>3</sup>University of Science and Technology of China, Hefei 230026, China

<sup>4</sup>Key Lab of Environmental Optics & Technology, Anhui Institute of Optics and Fine Mechanics, Chinese Academy of Sciences, Hefei 230031, China

<sup>5</sup>Advanced Laser Technology Laboratory of Anhui Province, Hefei 230037, China

*Received: 12 April 2022*

*Accepted: 21 June 2022*

## Abstract

At present, gas monitoring technology based on optical principle has been widely used in atmospheric environment, industrial emissions, smart city and other monitoring fields. For the requirement of high precision and high stability control of temperature and pressure of laser absorption spectroscopy measuring instrument, the temperature and pressure control scheme of the system is studied. The temperature and pressure control system is identified and the simulation model is established. The consistency of temperature and pressure models is 99.35% and 95.55% by using Process Models module to debug continuously. The simulation compares the output response curves of different control methods with the same step signal input, and the Fuzzy Adaptive PID parameter control algorithm achieves the design requirements in response time, overshoot and other aspects.

**Keywords:** gas monitoring technology, laser absorption spectrometric measurement, temperature and pressure control, system identification, Fuzzy Adaptive PID

## Introduction

Following China's industrial construction, economic development by leaps and bounds, "carbon" consumption is also increasing with each passing day.

Accurate and stable gas detection plays an important role in air pollution prevention and industrial production [1-4]. With the development of laser absorption spectroscopy and optoelectronic devices [5-8], TDLAS and other related technologies are gradually applied, and have been widely used in industrial production, natural environment, diagnosis and treatment, food and many other industries [9-12]. In the process of the development of laser absorption spectrum measurement

---

\*e-mail: zhangzr@aiofm.ac.cn

instruments, scholars at home and abroad are constantly improving the detection limit and stability of measurement, and have done a lot of research on the influence of temperature and pressure on measurement accuracy [13-16].

At present, the manufacturers who can provide spectral measurement instruments include ABB of Canada [17-18] and Picarro of the United States [19-22], whose products cover all kinds of greenhouse gas detection in various industries. In China, Hangzhou Focused Photonics Inc, Anhui Institute of Optics and Precision Machinery of the Chinese Academy of Sciences and Ningbo Haiertech Optoelectronic Technology Co., Ltd. can provide TDLAS gas analysis instruments in small batches. Most universities and research institutes are still in the laboratory research stage, which is still a long way from field application. The main problems of laser trace gas analyzer in small batch production include instrument control accuracy and so on, which will directly affect the stability of the analyzer.

From the principle of spectral measurement, it can be seen that the changes of temperature and pressure will affect the shape and intensity of spectral lines, the absorption of gas molecules and other physical quantities. In the process of studying the on-line detection technology of industrial engineering gas, Pang Tao [23] of Anguang Institute discussed the influence of temperature and pressure on the detection, and carried out correction experiments. It is pointed out that gas calibration is generally carried out at room temperature and pressure, and the change of temperature and pressure will cause large measurement errors. Cao Ke et al. [24] studied the temperature control of the decaying optical cavity and realized the fluctuation control of 0.05°C at 31°C through experiments. The standard deviation of temperature change is less than 0.01°C, which can effectively improve the stability of the measuring device. Han Yan of Anguang Institute [25] designed a set of CO<sub>2</sub> gas molecular stable isotope abundance detection system to control the temperature and pressure of the integral cavity. The temperature is 296K, the pressure is 100 mbar and the pressure control precision is 1 mbar.

The stability control of temperature and pressure is very important for the stability and accuracy of spectral measurement results. However, the current research in this field can not reach the level of commercial instruments in Europe and the United States, which is a major obstacle to the production of laser absorption spectrum instruments, which is also the original intention of this study, hoping to solve this problem in engineering. Some organizations and researchers have also carried out varying degrees of research on temperature and pressure control in other fields [26-27]. The control theories and methods they use will also be used for reference to solve the problem of temperature and pressure control in laser absorption spectroscopy measurement from an engineering point of view.

## Basic Principle

### Principle of Absorption Spectrum Measurement

When the laser absorption spectroscopy technology is used for the detection of trace gas concentration, the laser at a specific frequency passes through the absorption pool of the mixed gas sample to be measured, and the measured transmitted light spectral information is obtained. After spectral processing and calculation, the volume fraction of the gas to be measured in the mixed gas can be obtained, and its relationship is as follows:

$$I_t = I_0 \exp[-S(T)CPL\phi(\nu)] \quad (1)$$

Where,  $\nu$  is the incident light wave number;  $C$  is the volume concentration fraction;  $L$  is optical path;  $P$  is the gas pressure;  $T$  is the gas temperature;  $\phi(\nu)$  is the absorption linear function obtained after normalization of integral area;  $S(T)$  [cm<sup>-2</sup>atm<sup>-1</sup>] is the spectral intensity of absorption spectral line at temperature  $T$ .

The change of temperature will cause the change of the opto-mechanical structure and the temperature of the target gas in the laser absorption spectrum measurement equipment, which will lead to the change of the refractive index of the target gas, thus affecting the measurement results. The temperature field can be expressed by the heat conduction equation:

$$\frac{\partial T}{\partial \tau} = a\nabla^2 T = \frac{\lambda}{c\rho} \left( \frac{\partial T^2}{\partial x^2} + \frac{\partial T^2}{\partial y^2} + \frac{\partial T^2}{\partial z^2} \right) \quad (2)$$

$\tau$  is time,  $T$  is temperature,  $A$  is thermal diffusivity of the material,  $\lambda$  is thermal conductivity,  $\rho$  is density,  $c$  is specific heat capacity,  $x$ ,  $y$  and  $z$  are spatial coordinates.

### Digital PID Control Principle

Digital PID control is one of the common basic theories in control technology. It applies the calculation function of embedded system to the basic theory of PID control, and completes PID control and variable value adjustment with computer language, which can make the control more flexible. Therefore, the continuous data information of PID control must be discretized. Trial-and-error methods are commonly used in specific control applications and can be divided into positional and incremental methods.

The positional method usually discretizes continuous integration and differentiation. When the following similar formula becomes a different equation:

$$\int_0^1 e(t) dt \approx T \sum_{i=0}^k Te(iT) = T \sum_{i=0}^k e(i) \quad (3)$$

$$\frac{de(t)}{dt} \approx \frac{e(kT) - e[(k-1)T]}{T} = \frac{e(k) - e(k-1)}{T} \quad (4)$$

Where, T is the sampling period time, k (1,2,3...) is the sampling frequency, and then the integral and differential calculation is replaced by the standard value and the first-order backward differential signal calculation. Then the position algorithm formula of discrete variables at k sampling moments can be expressed as:

$$u(k) = K_p \left[ e(k) + \frac{T}{T_I} \sum_{i=0}^k Te(i) + T_D \frac{e(k) - e(k-1)}{T} \right] \quad (5)$$

Formula (5) can be improved to obtain the expression formula of u (k-1) sample output:

$$u(k-1) = K_p \left[ e(k-1) + \frac{T}{T_I} \sum_{i=0}^k Te(i) + T_D \frac{e(k-1) - e(k-2)}{T} \right] \quad (6)$$

The difference between the above two formulas (5) and (6) can be calculated as follows:

$$\begin{aligned} \Delta u_k &= u_k - u_{k-1} \\ &= K_p \left[ e_k - e_{k-1} + \frac{T}{T_I} e_k + T_D \frac{e_k - 2e_{k-1} + e_{k-2}}{T} \right] \\ &= K_p \left( 1 + \frac{T}{T_I} + \frac{T_D}{T} \right) e_k - K_p \left( 1 + \frac{2T_D}{T} e_{k-1} + K_p \frac{T_D}{T} e_{k-2} \right) \\ &= A e_k - B e_{k-1} + C e_{k-2} \end{aligned} \quad (7)$$

According to the above formula, after the values of A, B and C are determined, three deviation values can be calculated after A sampling period, and then the control output can be obtained. The Fuzzy Adaptive PID control (FA-PID) is based on incremental PID.

### Overall System Design

The overall design block diagram of temperature and pressure control system for laser spectrum measurement

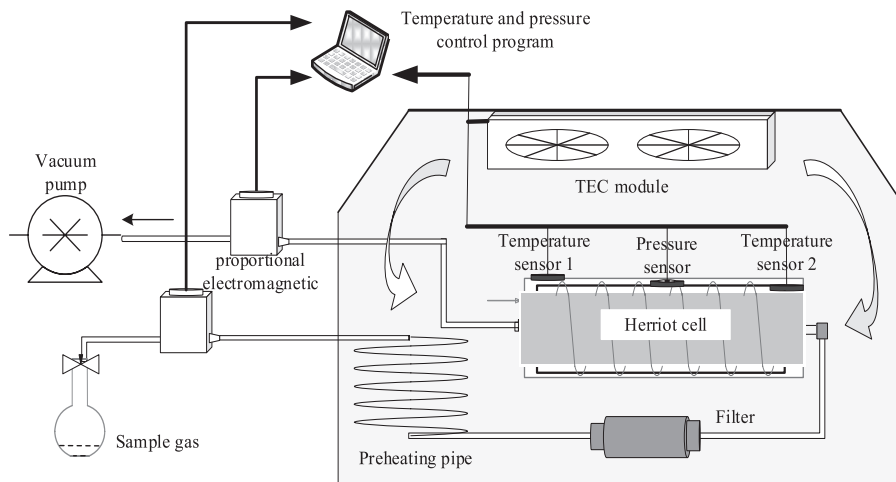

Fig. 1. Overall design block diagram of temperature and pressure control system for laser absorption spectrum measurement.

is shown in Fig. 1. The optical machine part of the laser spectrum measuring equipment is placed in a closed, dry and clean constant temperature chamber, and the chamber adopts passive vibration isolation method to achieve effective vibration isolation. The casing of the control system adopts the design of “convex” shape multi-layer insulation and semiconductor cooler. With PID control algorithm as the core, the temperature control unit is designed with high precision temperature sampling module, analog-to-digital conversion module, driving circuit module, etc. Pressure control unit includes flow meter, high precision pressure sensor, vacuum pump and so on. Finally, the long-term temperature change does not exceed 0.005°C; The negative pressure can be stably controlled in the range of 100~200 mbar, and the control accuracy can reach 0.2%.

### Temperature Control Scheme

Fig. 2 is a schematic diagram of temperature control scheme. When the ambient temperature changes, the resistance value of the temperature sensor changes accordingly, which can be converted into a potential difference using a constant current source, and then digital output through the analog-to-digital conversion circuit, and then transmitted to the embedded control system through the signal conditioning circuit. According to the difference between the set target temperature and the current temperature, the system adopts PID control algorithm to form a closed-loop control, and its output passes through MCU control unit, so as to change the voltage amplitude loaded by TEC and realize automatic temperature control.

### Pressure Control Scheme

Fig. 3 is a schematic diagram of pressure control scheme. The pressure in the cavity causes strain gauge deformation of the pressure sensor, resulting in

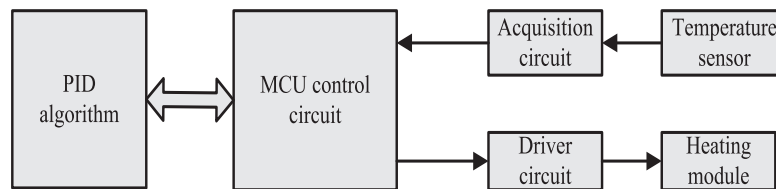

Fig. 2. Schematic diagram of temperature control scheme.

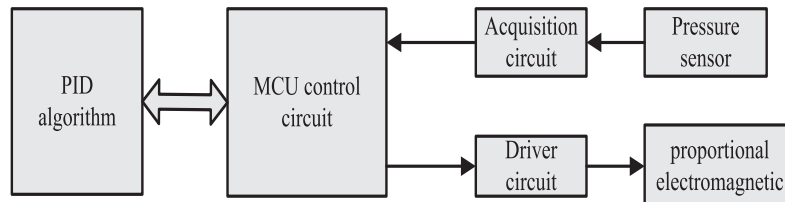

Fig. 3. Schematic diagram of pressure control scheme.

resistance change, which is converted into digital signal after A/D conversion. According to the test data, the control module of the pressure control system measures the current pressure value and compares it with the set pressure. After conversion, computer control data signal output to proportional solenoid valve, control gate valve opening.

## Control System Identification

### Analysis of Temperature Control System Model

The internal process of temperature and pressure control box used for laser absorption spectroscopy measurement is very complicated. It is obviously very difficult to use mechanism analysis method, even if the model is established, it is difficult to ensure its credibility, so experimental methods can be used to establish its model. In order to reduce the labor of manual calculation and reduce the deviation introduced by manual calculation, system identification auxiliary tools are used for identification. This auxiliary tool is a solution for sampling data information with discrete

variables. The key is a package that uses the least square structure for model identification. Its overall design is more effective, clear and extensible, so it has been selected by many researchers. Fig. 4 is a schematic diagram of this experiment.

The operating system works under the required test load. After running stably for a period of time, the input of the system can be rapidly changed. Meanwhile, the input, output and conversion curves of the system can be recorded together with the data acquisition system. After a period of operation, the system will enter a new steady state. This curve in the middle can be thought of as the step response of the system. During the testing process, a step signal is applied to the controlled object TEC, and the temperature change is collected and measured at the sampling rate of 1S, and the corresponding relationship between time and temperature change is recorded. The step response curve is shown in Fig. 5.

Considering the characteristics of multi-layer box structure and temperature change, and referring to the research of many scholars, the transfer function should be hysteretic model. The model parameter identification is mainly completed by Matlab.

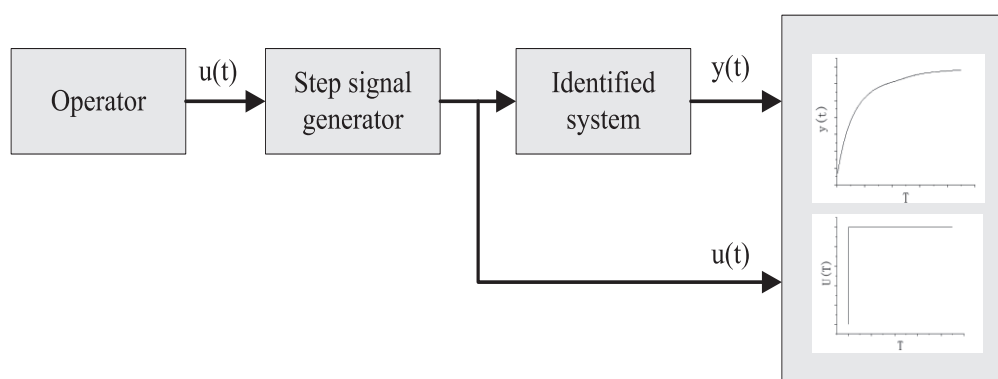

Fig. 4. Schematic diagram of system identification experiment.

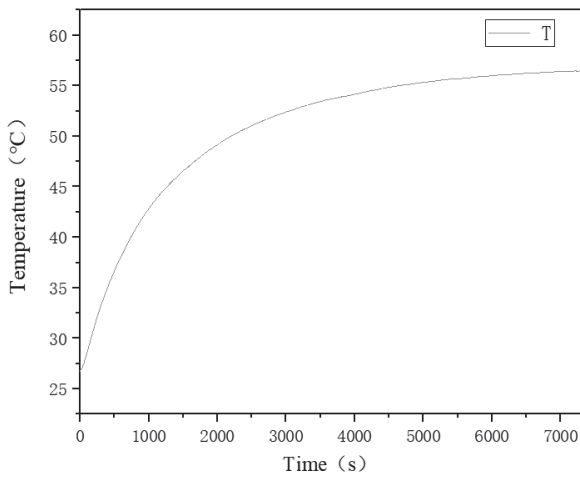

Fig. 5. Step response results of the system.

The system identification toolbox of Matlab can Process the discrete sampling data. The Process Models module is used to adjust the parameters of the model and obtain the best value. Finally, the optimal mathematical model of temperature control equipment is clarified. The first - order hysteresis model and the second - order hysteresis model are selected to distinguish the conduction process. By comparison, the relationship is as follows:

$$G_1(s) = \frac{k_0}{T_s + 1} e^{-\tau} \tag{8}$$

$$G_2(s) = \frac{k_0}{(T_{p1} + 1)(T_{p2} + 1)} e^{-\tau} \tag{9}$$

The output curve of the response system model shown in Fig. 6 can be obtained by analyzing the

experimental data of the above two lag models. Through comparison, it can be found that the second-order model has a higher coincidence degree. After the second-order model was adopted, the Process Models module was used for continuous debugging, and the second-order delay model parameters with satisfactory coincidence were finally obtained, which reached 99.35%, laying a foundation for subsequent algorithm research.

The model output in Fig. 6 is basically the same as the actual output. Because the control loop has a certain robustness, the difference between the actual system and the simulation model can be regarded as the disturbance in the simulation, and the closed-loop control adopted in the experiment can eliminate the system disturbance. Therefore, the model meets the practical application conditions and can be modeled mathematically. Finally, the temperature control model of laser absorption spectrum discriminated by us is as follows:

$$G_2(s) = \frac{1.1308}{(1798.3s + 1)(515.87s + 1)} e^{-10s} \tag{10}$$

### Analysis of Pressure control System Model

The pressure control system in this paper mainly includes: high-precision pressure sensor, proportional control valve, KNF vacuum pump and control circuit, as shown in Fig. 7.

It can be seen from the model that this is a nonlinear system and the transfer function is very complex. Therefore, the same method is adopted to identify the temperature control system. Through comparison, it can be found that the second-order model has a higher coincidence degree. In order to reduce the system complexity and facilitate the study, a second-order delay-free model was adopted, and the Process Models

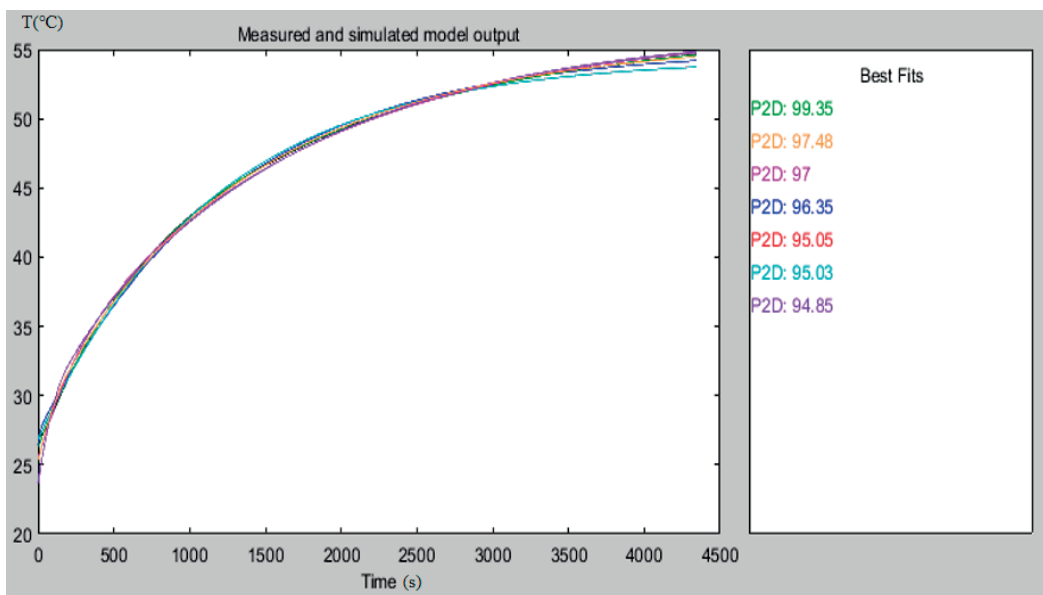

Fig. 6. Comparison of temperature control simulation models.

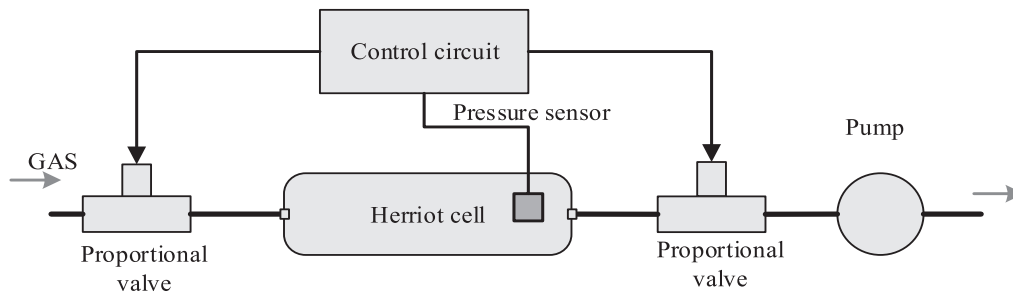

Fig. 7. Pressure control system scheme.

module was used for continuous debugging. Finally, satisfactory model parameters were obtained with a compliance of 95.55%, as shown in Fig. 8.

The model output in the figure is basically the same as the actual output. Due to the robustness of the control loop, there will be a certain difference between the actual system and the simulation results, which can be considered as the disturbance in the simulation. And the experiment is closed loop control, the system

disturbance can be eliminated. Therefore, the model meets the practical application conditions and can be modeled mathematically. Finally, the pressure control model of laser absorption spectrum analyzed by us is as follows:

$$G_2(s) = \frac{2.4924}{(308.3s+1)(25s+1)} \quad (11)$$

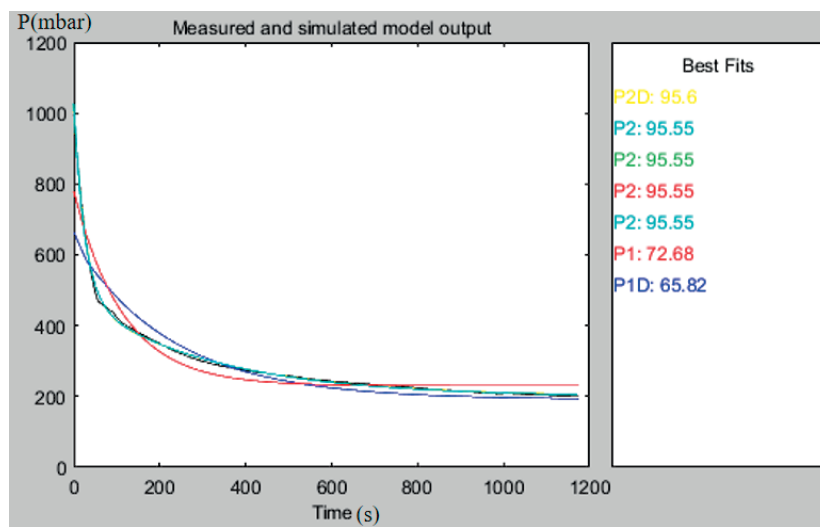

Fig. 8. Pressure simulation identification comparison.

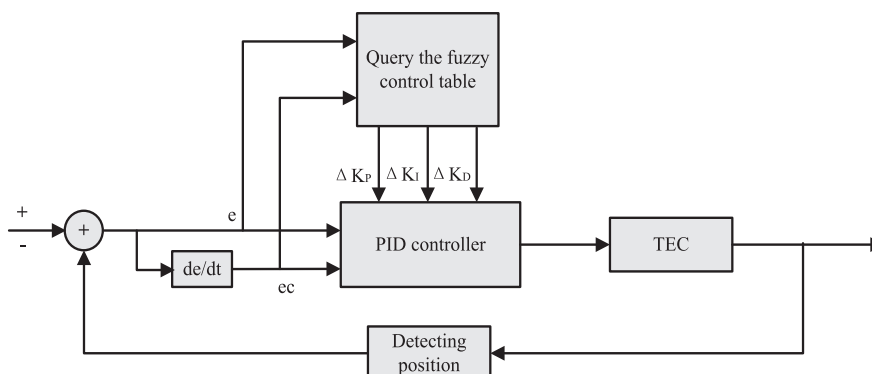

Fig. 9. FA-PID structure block diagram.

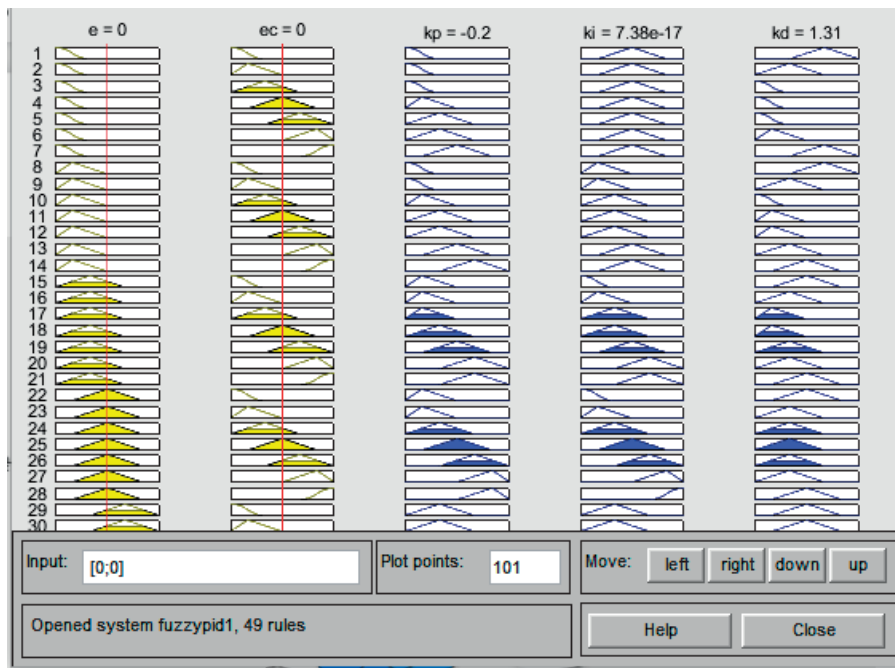

Fig. 10. FA-PID control rules.

### FA-PID Control Algorithm

#### The Algorithm Structure

Due to the second-order delay characteristic of the temperature control system software, once the external environment changes, the stability of the temperature control system will deteriorate due to the different input and output rates of the system. So it is very difficult to establish an accurate mathematical analysis model of system software directly. The accuracy of the temperature model discriminated above cannot reach 100%. In order to better deal with this problem, this

section takes the temperature FA-PID controller as an example to describe the design process of the system in detail, and carries out simulation with the help of software. Fuzzy inference machine is introduced into PID controller to complete fuzzy optimization control. According to the design characteristics of the system, the traditional digital PID control method of temperature and pressure measurement of laser spectrum is fuzzy and adaptive algorithm is used. According to the response of the system software, the controller can be adjusted in real time to achieve higher actual control effect. The framework is shown in Fig. 9.

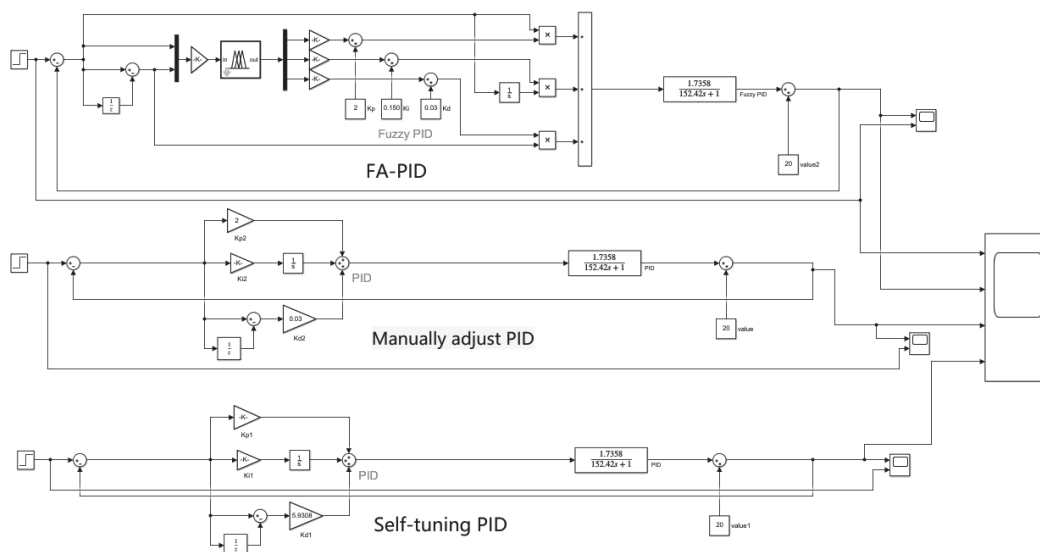

Fig. 11. Matlab simulation model.

## Fuzzy Input and Output

In the design, we define the temperature FA-PID controller of the laser absorption spectrum system as two inputs E and EC, and the outputs are  $\Delta KP$ ,  $\Delta KI$ ,  $\Delta KD$ . According to E and EC, the parameters of fuzzy-PID controller are adjusted. The variable domains of E and EC are  $\{-6, -4, -2, 0, 2, 4, 6\}$  and  $\{-3, -2, -1, 0, 1, 2, 3\}$ , and then they are divided into seven levels with the language values of  $\{NB, NM, NS, ZO, PS, PM, PB\}$ .

## Inference Rule Library

Fuzzy control rule base is the core of FA-PID controller. In order to make the control rules more consistent with the characteristics of the system, the design method of the Fuzzy control rule base is as follows: First, in the Fuzzy toolbox, according to the empirical formula, the system is simulated and the response curve is obtained. Thus continuously adjust the fuzzy control rule table. According to this principle, the basic principles of adaptive fuzzy control rule table for setting temperature are as follows:

When e is large, small KD and large KP should be used to make the system have better tracking performance. At the same time, the integral size should be limited, generally set as  $KI = 0$ . This avoids large overshoot of system software response.

When E is at moderate levels for long periods, KP should be smaller to better enable the system to respond to smaller overshoots. In this case, the value of KD is very bad for the system, and the value of KI should be appropriate.

When E is relatively small, KP and KI should be large to improve system stability. At the same time, KD value should be selected according to EC value in order

to prevent isoamplitude oscillation of the system. If EC is large, then KD should be small.

## Simulation Experiment and Discussion

### Simulation Model

The temperature control system simulation model of laser spectrum measurement system was established, and the relevant parameters of the control system were adjusted through the established control simulation model, in order to get the best control effect. In this paper, Matlab was used for simulation. Firstly, set the input, output and system function of temperature control system, and then input the results of the experiment into the rule editor. KP, KI and KD rules, as shown in Fig. 10.

As shown in Fig. 11, three models are established in Matlab according to the determined optimal model function of the system, and the simulation output results are compared and analyzed. Among them, the traditional PID controller is adjusted by critical proportion method. First, the proportional coefficient (KP) of PID controller is set to the maximum, the integral time is increased as much as possible, and the differential time is set to zero. Then, the proportional coefficient (KP) is gradually reduced. When the output response curve turns into constant amplitude oscillation, the proportional coefficient (KP) and oscillation period are obtained.

### Simulation Results

After the system platform was built, the response curves of the three temperature controllers were

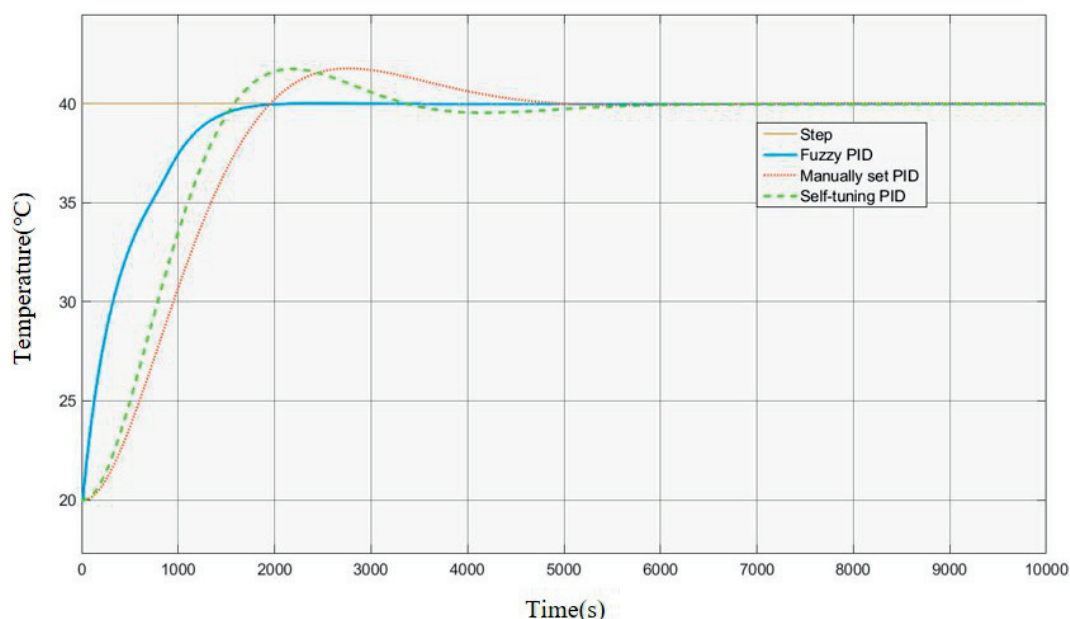

Fig. 12. Simulation results of PID algorithm.



simulated and compared. The simulated output is shown in Fig. 12. Yellow solid line: input step signal, dotted line: output response of traditional PID, dotted line: output response of self-tuning PID, solid line: output response of FA-PID. The results show that the fa-PID controller has almost no overshoot, and the control effect is better than the two controllers. Even if the simulation results of the created temperature control system model are ideal, errors are inevitable in the actual test due to the inconsistent gain values of the system entity model and the influence of the data signals of the unstable natural environment.

### Conclusion

This paper mainly studies the following aspects in system identification method and control method:

1. In view of the influence of temperature and pressure changes on the measurement process of laser absorption spectrum technology, a system scheme for temperature and pressure control of the measurement system is proposed. It is required that the temperature fluctuation of the passing light part of the measuring system shall not exceed 0.005°C for a long time, and the pressure control system can achieve the stable negative pressure of 100~200 mbar, and the accuracy can reach 0.2%. In view of the above requirements, the design block diagram of temperature and pressure control is determined.

2. In order to implement internal environment on the laser absorption spectrum measurement system of high accuracy high stability control, first of all, it is necessary to establish the control system of temperature and pressure the best mathematical analysis model, it is beneficial to the temperature and pressure control algorithm to optimize the online simulation debugging, and then find the best strategy design, and explore its essence. The mathematical model of temperature control system is analyzed by step response method, and then the mathematical model of pressure control system is analyzed by correlation analysis method.

3. After the mathematical model is determined, in order to achieve better control accuracy, it is necessary to set the parameter values of PID controller. This parameter is of great significance to improve the dynamic and static data characteristics of the system and the characteristics of the decision controller. In order to solve the analysis model is not accurate, input and output rate of sync, vulnerable to the influence of changing external environment factors, such as a series of problems may affect the precision of PID control, the system proposes the fuzzy control is introduced into the laser absorption spectrum measuring system of temperature and pressure control, the application scope of the control system more widely.

### Acknowledgments

This work is supported by National Natural Science Foundation of China (Nos. 11874364, 41877311, 42005107, 41773100), External Cooperation Program of Chinese Academy of Sciences (No. GJHZ1726), Key Research and development project of Anhui Province (Nos. 201904c03020005, 1804a09020097), Major scientific and technological projects in Anhui Province (No. 18030901054), Support program for outstanding young talents in Colleges and universities of Anhui Province (No. gxyq2020061), Natural Science Research project of Bengbu College (Nos. BBXY2022KYQD04, 2019ZR03zd).

### Conflict of Interest

There are no conflicts to declare.

### References

- LIU W.Q., CHEN Z.Y., LIU J.G. Stereoscopic monitoring technology and applications for the atmospheric environment in China [J]. Chinese Science Bulletin, **61** (30), 3196, **2016**.
- SAMPAOLO A., PATIMISCO P., GIGLIO M. Quartz-enhanced photoacoustic spectroscopy for multi-gas detection: a review [J]. Analytica Chimica Acta, 338894, **2021**.
- ZHANG Z., SUN P., LI Z. Novel Coalbed Methane (CBM) Origin Analysis and Source Apportionment Method Based on Carbon Isotope Ratio Using Infrared Dual-Wavelength Laser Absorption Spectroscopy [J]. Earth and Space Science, **5** (11), 721, **2018**.
- XU L., ZHIRONG Z., PENGSHUAI S. Design of High Precision Temperature and Pressure Closed-Loop Control System for Methane Carbon Isotope Ratio Measurement by Laser Absorption Spectroscopy [J]. Polish Journal of Environmental Studies, **31** (1), 969, **2022**.
- INNOCENTI F., ROBINSON R., GARDINER T. Differential absorption lidar (DIAL) measurements of landfill methane emissions [J]. Remote Sensing, **9** (9), 953, **2017**.
- BLUME N.G. Supercontinuum Absorption Spectroscopy for Combustion Diagnostics [D]; Darmstadt, Technische Universität, **2019**.
- HALLORAN M.P. Application of Supercontinuum Laser Absorption Spectroscopy (SCLAS) to Combustion Environments [D]; State University of New York at Buffalo, **2020**.
- BUTTON M.C. Development of TDLAS Diagnostics for in situ Harsh Environment Water Vapor Temperature, Concentration, and Pressure Measurements [D]; The George Washington University, **2019**.
- SUN P., ZHANG Z., LI Z. A Study of Two Dimensional Tomography Reconstruction of Temperature and Gas Concentration in a Combustion Field Using TDLAS[J]. Applied Sciences, **7** (10), 990, **2017**.
- ZHANG Z., PANG T., YANG Y. Development of a tunable diode laser absorption sensor for online monitoring of industrial gas total emissions based on optical scintillation

- cross-correlation technique [J]. *Optics Express*, **24** (10), A943, **2016**.
11. POGÁNY A., WAGNER S., WERHAHN O. Development and metrological characterization of a tunable diode laser absorption spectroscopy (TDLAS) spectrometer for simultaneous absolute measurement of carbon dioxide and water vapor [J]. *Applied spectroscopy*, **69** (2), 257, **2015**.
  12. QU S., WANG M., LI N. Mid-Infrared Trace CH<sub>4</sub> Detector Based on TDLAS-WMS [J]. *Guang pu xue yu Guang pu fen xi= Guang pu*, **36** (10), 3174, **2016**.
  13. HUA X., FENG-ZHONG D., BIAN W. Sensitive absorption measurements of hydrogen sulfide at 1.578  $\mu\text{m}$  using wavelength modulation spectroscopy [J]. *Chinese Physics B*, **24** (3), 034204, **2015**.
  14. HAN L., CHEN X., XIA H. A photocoustic spectroscopy system for gas detection based on the multi-pass cell [C]. *Advanced Sensor Systems and Applications VII*, 10025, 10025N, **2016**.
  15. XU L.I.U., PENG-SHUAI S.U.N., XI Y. High Precision Temperature Control Design for TDLAS Gas Detection System[J]. *Acta Photonica Sinica*, **49** (12), 93, **2020**.
  16. XI Y., PENGSHUAI S., TAO P. High Precision Temperature Control Design of Gas Cell in Laser Absorption Spectroscopy System [J]. *Acta Optica Sinica*, **40** (12), 1230001, **2020**.
  17. CHIARUGI A., VICIANI S., D'AMATO F. Diode laser-based gas analyser for the simultaneous measurement of CO<sub>2</sub> and HF in volcanic plumes [J]. *Atmospheric Measurement Techniques*, **11** (1), 329, **2018**.
  18. BURGUÉS J., MARCO S. Environmental chemical sensing using small drones: A review [J]. *Science of The Total Environment*, 748, 141172, **2020**.
  19. WASTINE B., KAISER C., VUILLEMIN C. Evaluation of the Picarro EnviroSense 3000i analysers (now called G1301) for continuous CO<sub>2</sub>/CH<sub>4</sub> measurements [C]. *EGU General Assembly Conference Abstracts*, 2562, **2009**.
  20. MARCHE B. A Climate Study in Western Newfoundland: Precipitation  $\delta^{18}\text{O}$  and  $\delta^2\text{H}$  Examination Using Picarro L2130-i Liquid Water Isotope Analyzer [D]; Memorial University of Newfoundland, **2016**.
  21. REUM F., GERBIG C., LAVRIC J.V. Correcting atmospheric CO<sub>2</sub> and CH<sub>4</sub> mole fractions obtained with Picarro analyzers for sensitivity of cavity pressure to water vapor [J]. *Atmospheric Measurement Techniques*, **12** (2), 1013, **2019**.
  22. CROSSON E. A cavity ring-down analyzer for measuring atmospheric levels of methane, carbon dioxide, and water vapor [J]. *Applied Physics B*, **92** (3), 403, **2008**.
  23. TAO P., YU W., HUA X.I.A. Full Scale Methane Sensor Based on TDLAS Technology [J]. *Acta Photonica Sinica*, **45** (9), 0912003, **2016**.
  24. CAO KE, LIANG CHAO-QUN, GUO RUI-MIN Study on Temperature Control for Ring-Down Cavity[J]. *Acta Metrologica Sinica*, **39** (3), 431, **2018**.
  25. HAN L., CHEN X., XIA H. A photocoustic spectroscopy system for gas detection based on the multi-pass cell [C]. *Advanced Sensor Systems and Applications VII*, 10025, 10025N, **2016**.
  26. BABURAJAN S. Pitch Control of Wind Turbine through PID, Fuzzy and adaptive Fuzzy-PID controllers [D]; Rochester Institute of Technology, **2017**.
  27. XU CHEN Optimization and Realization of Temperature Control System for Laser Crystal Based on Self-tuning Fuzzy-PID Parameter[D]; Anhui University of Technology, **2018**.