

Original Research

Study on the Rapid Integration of Emergency Logistics System for Accident-Type Disasters Based on the Concept of Green Sustainable Development

Wenxuan Ma^{1,2}, Xin Wen^{1*}, Jian Xu¹

¹School of Management, Shenyang University of Technology, Shenyang, Liaoning, 110870, China

²Graduate school, Criminal Investigation Police University of China, Shenyang, Liaoning, 110854, China

Received: 24 April 2024

Accepted: 19 July 2024

Abstract

The concept of green sustainable development is the inherent requirement of social and economic development construction. Meanwhile, with the frequent occurrence of accident-type disasters, the complex characteristics of them and the serious consequences to social and economic development have aroused people's concern. Therefore, this paper creatively combines green sustainable development and emergency logistics system construction and puts forward a method that can integrate "Case-based reasoning", "Modular design", "Orthogonal experiment design", and "Adaptive boosting", called "CMO-Adaboost" for short. It can increase the emergency rescue efficiency by 11.11%, emergency rescue capacity by 0.59%, and emergency rescue effect by 9.54%. It is feasible and can reduce economic losses and casualties in disaster-stricken areas, solve the problem of emergency resource waste, meet the needs of people's growing a beautiful ecological environment, and promote green sustainable development under the premise of integrating the concept of green sustainable development. The conclusion of this paper suggests the government should first focus on the internally driven components; namely "command layout", "policy supervision", "disposal and rehabilitation", and "integration and coordination". Secondly, attention needs to fall on the externally guided components; namely "innovative development" and "emergency plan". Thirdly, based on the concept of green sustainable development, as an intermediate connection component, the "information sharing" component, although equally important, is not the most priority component, but it can be moderately considered. This paper has reference value for other types of emergencies.

Keywords: green sustainable development, accident-type disasters, CMO-Adaboost, emergency logistics system, rapid integration

Introduction

Green is the necessary condition for sustainable development and the inherent requirement for socio-economic development; it can reflect people's pursuit of a better life and is widely concerned at present [1]. Green sustainable development is a mode of economic growth and social development with efficiency, harmony, and sustainability as the goal [2]. Accident-type disasters are accidents with disastrous consequences that can be directly caused by people's production and life activities; they can cause heavy casualties and social losses, against people's will, force the suspension of activities, or force a permanent stop [3]. The term System refers to a certain range or similar things in accordance with a certain order and connection combination of the whole; emergency logistics system refers to a special logistics system that is composed of multiple components around the emergency logistics goal [4] and rapid integration is the linking of discrete components to each other through some logic and philosophy, which can realize the cooperative work among various components in a short time [5]. Based on the concept of green sustainable development, the connotation of rapid integration of accident-type disasters emergency logistics system refers to connecting multiple components of the emergency logistics system with each other in a certain way to achieve internal coordination around the object of accident-type disasters and the goal of green sustainable development. The main essence of it is to combine scattered components together and eventually form a valuable and efficient whole. The conceptual condensation process of the rapid integration of accident-type disasters emergency logistics system based on the concept of green sustainable development is shown in Fig. 1. As can be seen from Fig. 1, the conceptual condensation process can realize the correlation or influence of the rapid integration results. In order to explore the rapid integration method of an accident-type disaster emergency logistics system, it is necessary to conduct a detailed analysis of its rapid integration demands. This paper explores the internal mechanism from the level of demand connotation and consists of two parts, which are the demands for rapid system integration of people and social conditions in the disaster area. The connotation of demands is shown in Fig. 2. As can be seen from Fig. 2, demands are not equal to needs; the rapid integration of an emergency logistics system for accident-type disasters needs superficial, specific, and complex emergency resources. However, the demands are the deep needs of the people and society in the disaster areas, and they must be summarized through the program of analysis and induction. From the perspective of solving the problem, the rapid integration of the system is the solution to meet the needs of the people in disaster-stricken areas. From the perspective of diversified needs, there are various integration methods to meet the needs of people in disaster-stricken areas. From the perspective of an equivalence relationship,

the demands for rapid integration of the system are not equal to the demands for personnel in the disaster areas, and the social demands in the disaster areas derive from the demands for rapid integration of the system.

At present, many countries have realized the rapid integration of emergency logistics systems needs to be included in the research focus. It is an important trend for many countries to take green sustainable development as an important measure to solve the problem of rapid integration of emergency logistics systems for accident-type disasters. The National Response Coordination Center of the United States is specifically responsible for providing national emergency logistics management coordination and information platform construction to respond to major disaster events. The Ministry of Emergency Situation of the Russian Federation has a number of emergency teams with advanced professional equipment to realize the integrated management of an emergency logistics system. According to Germany's own situation, the state Ministry of the Interior is responsible for the overall coordination, mainly the integration and coordination of various emergency logistics processes. In China, the government management departments have earnestly done some jobs in the emergency logistics system in response to public emergencies according to the overall plan. Most countries have paid special attention to the emergency rescue of accident-type disasters. The key to the integration of an emergency logistics system lies in the integration of its components. However, although some countries can be assisted by other countries' emergency logistics resources when accident-type disasters occur, these countries have not realized the rapid integration of their emergency logistics systems, which can affect the efficiency of emergency rescue. It is also not conducive to the implementation of the concept of green sustainable development.

Currently, some researchers have focused on emergency logistics integration technology and method [6-10], system construction and model research [11-13], policy and resource allocation research [14, 15], mechanism and management [16, 17], process and pattern [18, 19], system optimization and coordination [20-22], but no effective rapid integration methods of emergency logistics systems have been formed, which is the motivation for further research. The existing studies have mainly focused on technology, management, and model levels, lack theoretical command and generalization, cannot divide the complex issue of the integration of the emergency logistics system into several components of management, cannot reflect the internal characteristics of the problem through multiple attributes, and cannot be raised to the level of the integration of macro guidance and micro operation. The experience of a past single case cannot be used as a reference for new cases; the universality is weak.

Therefore, exploring the rapid integration method of emergency logistics systems for accident-type disasters based on the concept of green sustainable development

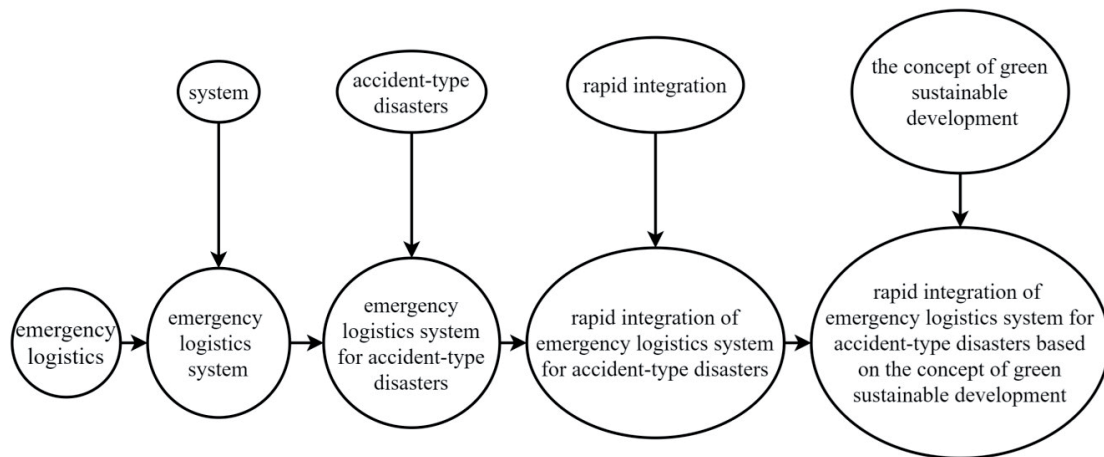

Fig. 1. The conceptual condensation process.

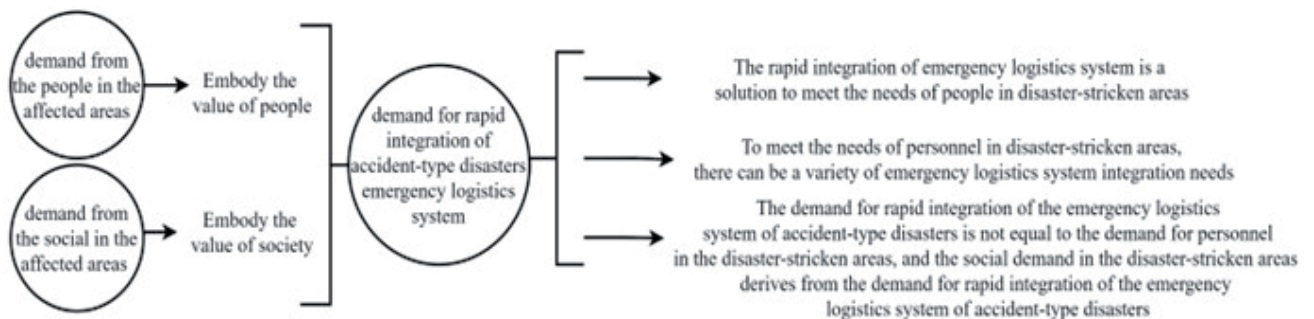

Fig. 2. The connotation of demands.

is urgent and has research value. It is related to the smooth progress of emergency logistics activities. It is the key to realizing emergency rescue and the focus of green sustainable development. This paper focuses on accident-type disasters in recent years, innovatively combines green sustainable development and emergency logistics system construction, and puts forward a rapid integration method of the emergency logistics system for accident-type disasters based on the concept of green sustainable development. It can explore the rapid integration methods of multiple components of the emergency logistics system, avoid excessive waste of emergency resources, avoid more casualties in disaster-stricken areas, and save economic losses. It can promote the realization of emergency rescue, verify the feasibility of the method with cases, and is also the value of the concept of green sustainable development.

Material and Methods

From the perspective of integrated macro-logic mechanisms, the improved CMO process can combine the advantages of CBR (Case-based reasoning), MD (Modular design), and OED (Orthogonal experiment design). In this process, the above three parts are

considered weak classifiers. On the basis of the previous basic classifier operation, a new weak classifier is added each round until a predetermined error rate is small enough or a pre-specified maximum number of iterations is reached, so as to achieve the purpose of combining the weak classifiers obtained by each training into a strong classifier, that is, to achieve adaptive boosting. When faced with new circumstances and problems, the research objectives change accordingly. CBR and MD can complete automatic case reasoning through the data system, according to the characteristics of the new case, while relying on the case's data that has occurred in the cases database. The conclusion of the OED optimization scheme is to rely on Matlab software to conduct numerical analysis of the original data. CMO ((CBR-MD-OED)) can further shorten the system integration time, save the data conversion time, reduce the extra time and economic cost loss generated in the process, improve the integration efficiency, promote green sustainable development, and realize the purpose of combining the weak classifiers obtained by training into strong classifiers. After that, a rapid integration scheme of the system is obtained through intelligent learning to further shorten the integration time and improve the integration efficiency, that is "Adaboost" (Adaptive boosting).

The "CMO-Adaboost" method technical route map, which can visually depict the workflow, is shown in Fig. 3. As can be seen from Fig. 3, the iterative calculation of this method can be divided into three steps, namely, initialization of weight distribution of training data (step 1), training of weak classifiers (step 2), and combination of all trained weak classifiers into strong classifiers (step 3). The CBR stage contains Step 1 and Step 2, the MD stage contains Step 1 and Step 2, the OED stage contains Step 2, and the "Adaboost" stage contains Step 3. When a new case occurs, the researchers need to find similar cases (the data samples refer to historical cases), and then cluster the components of the emergency logistics system. If there are N samples in the historical cases base, each training sample is given the same weight at the beginning: $1/N$. If a certain training sample point is accurately classified by the weak classifier, its corresponding weight should be reduced when constructing the next training set. Conversely, if a training sample point is mistakenly classified, its corresponding weight should be increased. The set of samples with updated weights

is used to train the next classifier, and the entire training process is iterated in this way. After the training of each weak classifier, if the weight of the weak classifier with a small classification error rate is increased, it can play a decisive role in the final classification function. If the weight of the weak classifier with a high classification error rate is reduced, it can play a less decisive role in the final classification function. In the improved "CMO-Adaboost" method, CMO stages can be considered weak classifiers, while the "Adaboost" stage can be considered a strong classifier. The method can systematically record and strictly examine the existing methods. Based on history, it can be simpler, more efficient, and environmentally and economically wise to achieve the goal of grasping reality and predicting the future. It can reduce the probability of secondary damage in disaster areas, reduce resource consumption and economic waste, and finally find a comprehensive, integrated, systematic, and practical way to shorten the integration time, meet the rapid integration needs of the system, and promote green sustainable development.

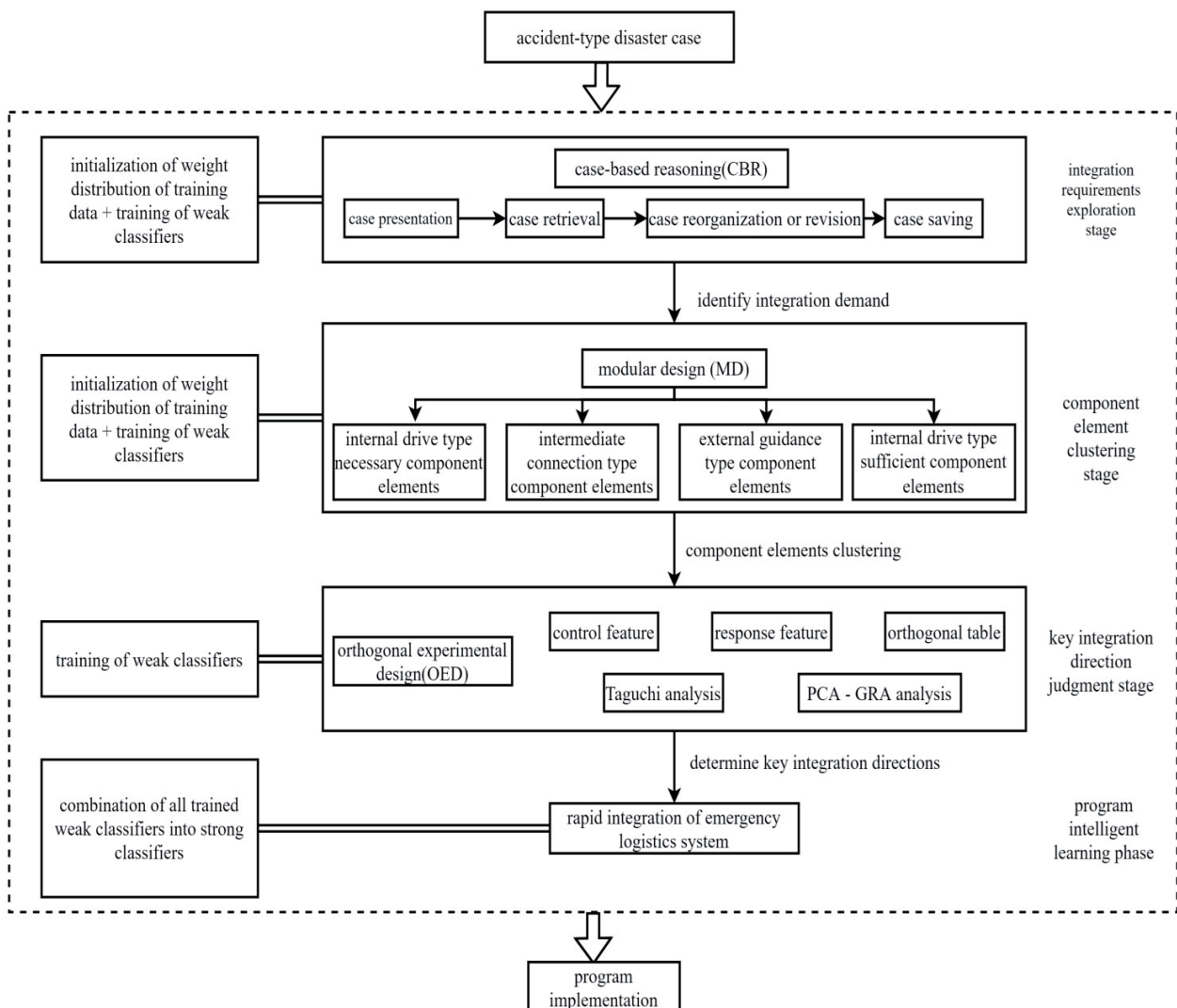

Fig. 3. The "CMO-Adaboost" method technical route map.

The advantages of the "CMO-Adaboost" method are as follows: Firstly, it can quickly retrieve the relevant data in the historical cases database, refer to the system demands of similar cases to solve the existing cases' problems, and the data retrieval process can be quickly completed by computers. Secondly, after locating similar cases, the complex problem of rapid integration of the system can be divided into several better-managed components layer by layer, that is, according to the relationship among the components of the similar cases' system, complete modular clustering. Thirdly, the rapid integration process of the system is affected by multiple control characteristics, and there are multiple response characteristics, and the application of Matlab software can obtain the integration scheme in a short time. Fourthly, it can improve the integration efficiency of systems, improve technology and processes, and carry out intelligent learning of the solutions. In summary, compared with previous studies, the "CMO-Adaboost" method is innovative, exploitable, efficient, and economical, which is conducive to the overall optimization of the system, the exploitation of the inherent potential, and the better realization of emergency rescue. Its focus is on program, operation, and action analysis; that is, the rapid integration process of the system is regarded as a system, that first focuses on various stages and micro-problems, relies on computer software, and then finally realizes the rapid integration and optimization of the system. In practical application, although the new cases have different attributes and characteristics, the rapid integration scheme of an emergency logistics system can be obtained in a short time based on the framework of the above method and promote green sustainable development. The process of rapid integration of the "CMO-Adaboost" method in the improved accident-type disaster emergency logistics system is based on the integration idea and analyzes the advantages and disadvantages of each other. The specific process is divided into four stages: integration demands exploration stage, components clustering stage, key integration direction judgment stage, and program intelligent learning stage.

Integration Demands Exploration Stage

CBR is considered the first stage of integration that demands exploration; it is a knowledge-based problem-solving and learning algorithm in the field of artificial intelligence. By finding historical cases similar to the new case, similar cases are reused and corrected to solve problems [23, 24]. CBR is a relatively mature branch in the field of artificial intelligence at present, and it is a reasoning based on past practical experiences. Its logical mechanism means that the conclusion of solving a new case problem needs to find the similar cases from the historical case base, and necessary changes should be made to adapt to the current problems. In the integration demands exploration stage, although the new case is characterized by abruptness,

randomness, and irregularity, it is difficult to describe it, but it can be input into the CBR system through case description, and the historical cases that are most similar to the target case can be automatically retrieved through case presentation, case retrieval, case reorganization or revision, case saving, and other aspects. The previously recorded data of a large number of cases contained in the case database can ensure the research results objectivity, improve the accuracy, reduce the subjective influence to a minimum, and determine the system integration demands. In this process, including case feature attribute weight calculation and case similarity calculation, the CBR system can judge the case similarity and make the output results implementable [25-27]. The process of CBR simplifies the classification process, quickly acquires the unregularized experience hidden in historical cases, and makes the conclusions reliable, and the solution results can be reused.

When a new accident-type disaster case occurs, the case is entered into the CBR system through the case description, and the system will retrieve the historical case that best matches the target case. If there is a source case that is consistent with the target case, the system integration demands of the historical cases can be directly exported, and the solution will be directly submitted to the government management department. If there are no historical cases that are basically consistent with the target case, the solution of similar cases will be adjusted and modified according to the situation of the target case. The government management department shall judge the adjusted solution according to the actual situation, adopt it if satisfied, and continue to adjust the solution if not satisfied. At the same time, the system will evaluate and learn from the satisfactory solution and save it to the cases database. The demand exploration path based on CBR is shown in Fig. 4. As can be seen from Fig. 4, the process generally includes case presentation, case retrieval, case reorganization or revision, and case saving. The demand exploration path based on CBR can improve accuracy, minimize subjective influence, and determine the integration needs of the emergency logistics system for accident-type disasters.

Components Clustering Stage

MD is considered the second stage of component clustering, and its application is to analyze, decompose, and re-plan related objects according to function and performance attributes to form different functional modules and reduce system complexity. The characteristic diagram is shown in Fig. 5. As can be seen from Fig. 5, the closeness of the connection among modules is proportional to the coupling and inversely proportional to the independence, which is deduced on the basis of approximate separability and loose coupling [28, 29]. Relying on MD, the components of the emergency logistics system will be analyzed, decomposed, and planned again according

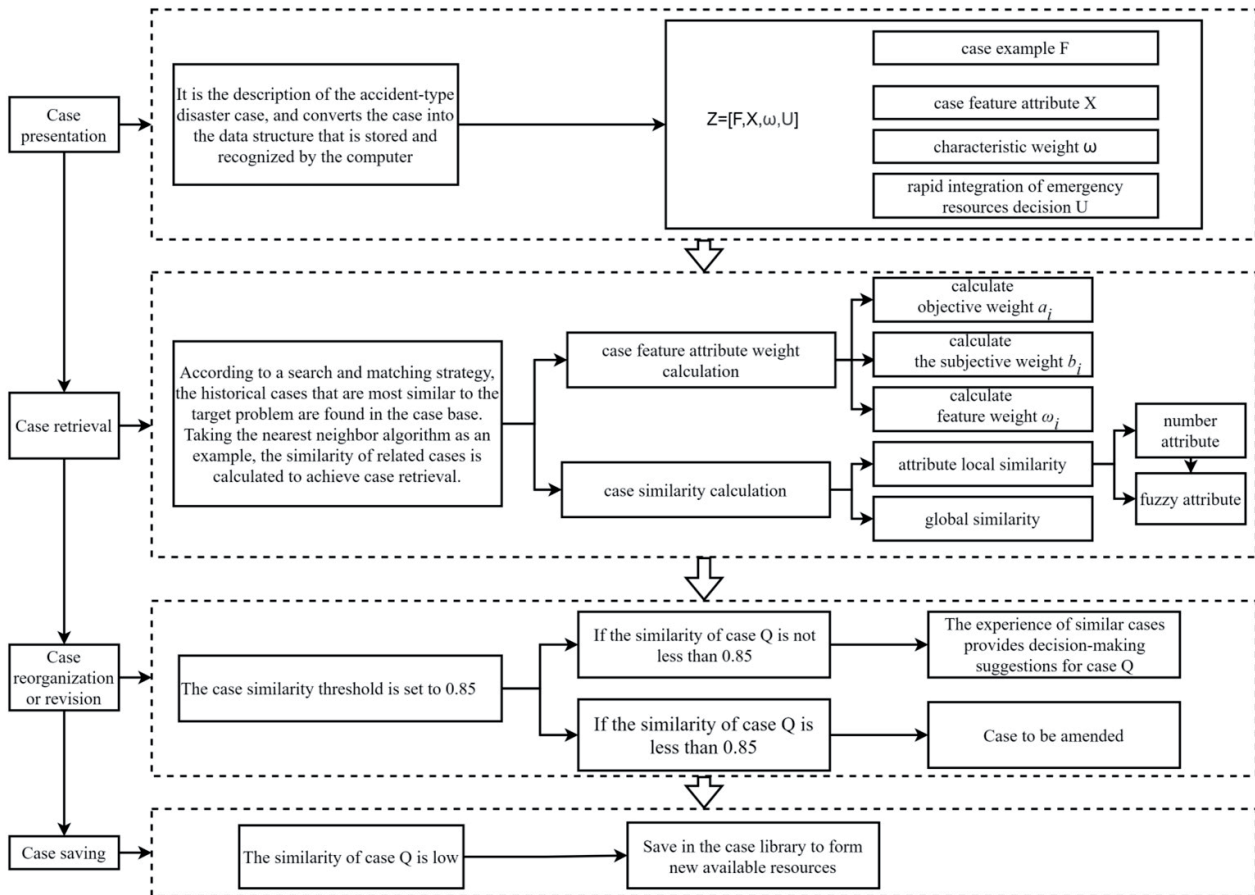

Fig. 4. The demand exploration path based on CBR.

to the function and performance attributes, form different functional modules, and reduce the complexity of the system. After the occurrence of accident-type disasters, the components of the emergency logistics system include various and complex categories. The essence is to divide the complex problem into several better-managed components layer by layer. Through various attributes, the internal characteristics can be reflected, respectively, and the integration time can be shortened, which has the advantage of making the integration process more independent and versatile. According to the functional characteristics of different components, similar functions can be summarized into a

module, and then a plurality of modules can be formed. The different modules are relatively independent, with high cohesion and low coupling property characteristics.

The aim of MD is to quickly integrate the components of an emergency logistics system to meet the demands of emergency rescue. Through the analysis in the previous stage, the government management department can determine the solution of similar cases in the past and determine the components of the emergency logistics system of similar cases. The purpose of modular design is to cluster these components and, through a comprehensive analysis of these components, divide and design a series of functional modules, which will be regarded as the control features in the orthogonal experiment design in the subsequent stage.

Key Integration Direction Judgment Stage

OED is considered the third stage of key integration direction judgment. Compared with the ordinary single-variable test method, it can avoid the loss of tests and calculation work, reduce resource consumption and economic waste, simplify the number of case tests, and obtain more valuable data [30]. Based on OED, the above components modules are set as factors, that is, control features and the relative importance and significance among them are compared to measure different feature

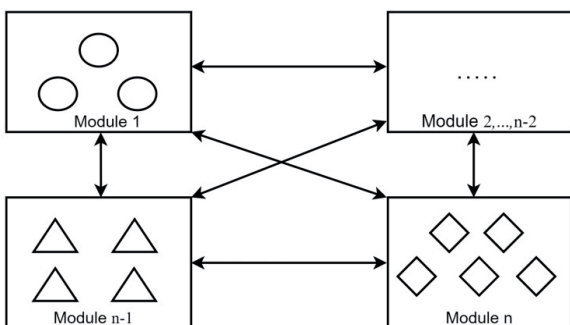

Fig. 5. The characteristic diagram.

levels, providing a theoretical basis for integrated decision-making [31-33]. The response characteristics are determined according to the Delphi method. The influence of control characteristics on response characteristics is evaluated by means of calculating the signal-to-noise ratio (SNR). Grey correlation analysis (GRA) is adopted, and the control features are required to comply with the orthogonal table design criteria based on several cases that had occurred. As there are multiple response features in the study, they are all affected by multiple control features to different degrees, so a multi-objective optimization model is constructed and feasibility is verified. The signal-to-noise ratio is adopted (SNR) to evaluate the influence of control features on response features. To evaluate and analyze the significance of the influence of control features on response features. Results are divided into STB type, NTB type, and LTB type, as shown in Equation (1) [34].

$$SNR = \begin{cases} -10\lg\left(\frac{1}{n}\sum_{i=1}^n y_i^2\right) & \text{STB} \\ -10\lg\left[\frac{1}{n}\sum_{i=1}^n (y_i - m)^2\right] & \text{NTB} \\ -10\lg\left(\frac{1}{n}\sum_{i=1}^n \frac{1}{y_i^2}\right) & \text{LTB} \end{cases} \quad (1)$$

In equation (1), n is the total number of experiments, y_i is the result of experiment i , and m is the target value of y_i . Combined with GRA, the multi-response feature optimization problem is transformed into a single response feature optimization problem, and the weight of the gray relational coefficient (GRC) is calculated by principal component analysis (PCA). In order to reduce the absolute difference among experimental data, the original data is normalized. Similar to SNR, it can be divided into three types, namely STB, NTB, and LTB, as shown in Equation (2) [34].

$$x_i(k) = \begin{cases} \frac{\max y_i(k) - y_i(k)}{\max y_i(k) - \min y_i(k)} & \text{STB} \\ \frac{\max |y_i(k) - a(k)| - |y_i(k) - a(k)|}{\max |y_i(k) - a(k)| - \min |y_i(k) - a(k)|} & \text{NTB} \\ \frac{y_i(k) - \min y_i(k)}{\max y_i(k) - \min y_i(k)} & \text{LTB} \end{cases} \quad (2)$$

In Equation (2), $i = 1 \sim 25$, $k = 1 \sim 3$; $y_i(k)$ is the raw data; $a(k)$ is the target value of $y_i(k)$; $x_i(k) \in [0,1]$, $x_i(k)$ is the result of SNR normalization. After normalization processing, the GRC calculation is completed, as shown in Equations (3)-(8) [35-37].

$$\zeta_i(k) = \frac{\min_i \min_k |x_0(k) - x_i(k)| + \eta \max_i \max_k |x_0(k) - x_i(k)|}{|x_0(k) - x_i(k)| + \eta \max_i \max_k |x_0(k) - x_i(k)|} \quad (3)$$

In Equation (3), $\zeta_i(k)$ is GRC; $x_0(k)$ is the ideal value of $x_i(k)$; $\eta \in [0,1]$ is the resolution factor. Normally, $\eta \in 0.5$. The contribution of the response features to the weighted sum-sum (GRG) of GRC is as follows:

$$\zeta = \begin{bmatrix} \zeta_1(1) & \zeta_1(2) & \cdots & \zeta_1(n) \\ \zeta_2(1) & \zeta_2(2) & \cdots & \zeta_2(n) \\ \vdots & \vdots & \ddots & \vdots \\ \zeta_m(1) & \zeta_m(2) & \cdots & \zeta_m(n) \end{bmatrix} \quad (4)$$

In equation (4), the number of OED $m = 25$, the number of response features $n = 3$. The PCA correlation coefficient matrix is calculated as follows:

$$R(j,l) = \left\{ \frac{\text{cov}[\zeta_i(j), \zeta_i(l)]}{\sigma_{\zeta_i(j)} \sigma_{\zeta_i(l)}} \right\} \quad (5)$$

In Equation (5), $j, l = 1, 2, \dots, n$; $\text{cov}[\zeta_i(j), \zeta_i(l)]$ is the covariance of $\zeta_i(j)$ and $\zeta_i(l)$; $\sigma_{\zeta_i(j)}$ and $\sigma_{\zeta_i(l)}$ are standard deviation of $\zeta_i(j)$ and $\zeta_i(l)$. The eigenvalues and eigenvectors of R are calculated as follows:

$$(R_{\text{PCA}} - \lambda_k I) V_{ik} = 0 \quad (6)$$

In Equation (6), λ_k is the eigenvalue, $\sum_{k=1}^n \lambda_k = n$; V_{ik} is the characteristic V vector of the K th principal component; I is the identity matrix. The weight calculation method of the K th principal component is as follows:

$$W_k = \frac{\lambda_k}{\sum_{k=1}^n \lambda_k} \quad (7)$$

The cumulative weights of the l st to the m th principal components are calculated as follows:

$$\sum_{k=1}^m W_k = \frac{\sum_{k=1}^m \lambda_k}{\sum_{k=1}^n \lambda_k} \quad (8)$$

When $\sum_{k=1}^m W_k > 85\%$, $\lambda_1, \dots, \lambda_m$ represents principal components l to m . The contribution rate of each response feature of the first principal component is generally considered the weight of the GRC, which is calculated as follows:

$$\alpha_i = V_{i1}^2 \quad (9)$$

In equation (9), Where α_i is the contribution rate of GRC; V_{i1} is the eigenvalue of the first principal component. Taking full account of the contribution

rates of each control feature, GRG is the weighted sum of response features to GRC, which can be expressed as follows:

$$\gamma = \sum_{i=1}^n \alpha_i \zeta_i \quad (10)$$

In Equation (10), γ stands for GRG; α_i represents the contribution rate of GRC, $\sum_{i=1}^n \alpha_i = 1$. After that, the

feasibility of the optimal control feature combination obtained by the multi-objective optimization is verified. The orthogonal experiment design and analysis process can be numerically analyzed and calculated by Matlab, and the final results are obtained to ensure rapidity. The advantage of OED is that it has no extremely strict restriction on the number of control features and whether there is an interaction among control features that cannot affect the scheme design. Experiments are compared according to the orthogonal table, and preliminary conclusions are obtained. The specific scheme is obtained through variance calculation and analysis, and the optimal control feature combination is obtained, which may already exist in the orthogonal test table. If it is not in the orthogonal test table, it can continue to verify.

Program Intelligent Learning Stage

"Adaboost" is considered the fourth stage of program intelligent learning and is the design step to realize the combination of weak classifiers into strong classifiers. This stage is based on the first three stages; each stage can reduce the shortcomings of the previous stage. However, if a similar case cannot be found in the case base or multiple similar cases are found at the same time, further judgment is needed, which will increase the original workload to a certain extent. In order to solve the above drawbacks, make this stage more intelligent, and promote green sustainable development, it is still necessary to continuously expand and update the number of cases in the future and constantly

optimize the case data. In addition, if multiple similar cases are found, accident-type disaster cases of similar types in the same region tend to be selected, so as to better combine regional, cultural, green sustainable development concepts, and other comprehensive factors to implement emergency work.

Based on the combination of the above advantages and complementary shortcomings, this paper studies the adaptive boosting in the intelligent learning stage of the scheme. The intelligent learning process is shown in Fig. 6. As can be seen from Fig. 6, the first three stages can identify similar cases in the historical cases base in a relatively short period of time, clarify the need for rapid integration of the system, carry out modular processing of the components, obtain the optimal combination of control features, and provide theoretical basis for the government management departments in a short period of time. The innovation of the program's intelligent learning stage lies in that when a new case occurs, the relevant process will be learned and the feedback data will be recorded in the historical cases base. In this stage, interactive response and adaptive learning will be made in time according to the actual situation and characteristics of the new case, so as to provide the learning content and path for the government management department to dynamically adjust the scheme and optimize the implementation suggestions in the future. This phase can ensure the timely response to new cases, ensure rationality, and protect the safety of people's lives and property in the disaster-stricken area in the future.

In addition, at present, government management departments attach great importance to artificial intelligence, vigorously support artificial intelligence, and have launched a series of encouraging policies. Program intelligent learning is a concern to accelerate the development of a new generation of artificial intelligence; its future research prospects are considerable, but the in-depth analysis of the possible social impact of program intelligent learning is the focus of future research. Program intelligent learning will continue to combine more artificial intelligence technologies in the future, deepen and promote the overall development of artificial intelligence technology

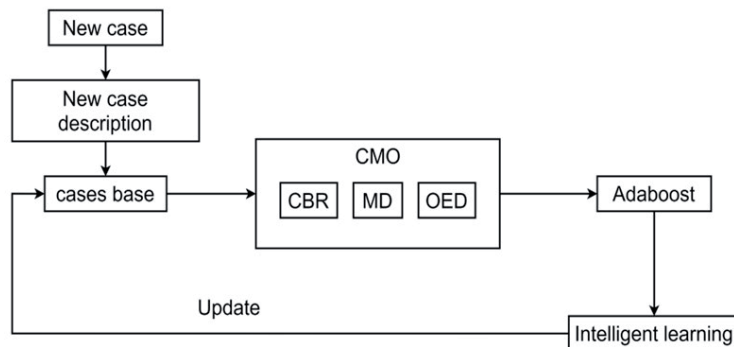

Fig. 6. The characteristic diagram.

while ensuring green sustainable development, and pay more attention to the privacy protection and data security of emergency logistics process data. At the same time, the process of relevant policies, laws, and regulations should also be accelerated, which is also the future research direction of intelligent learning and green sustainable development.

Results and Discussion

Taking a new accident-type disaster case Q as an example, the "CMO-Adaboost" method can be adopted. In CBR, to first express and describe Q, it has been transformed into a data structure that can be stored and recognized by a computer, find the most similar historical cases in the case database, calculate the similarity of related cases, and realize case retrieval. This process includes determining the characteristics and attributes of the cases, calculating the similarity, and judging the similarity threshold. Finally, it is determined that case W in the historical cases base is similar and does not need to be amended, and the rapid integration demands of W's emergency logistics system are taken as the demands of Q. The conventional accident-type disaster cases in the historical cases database include accident fire, traffic accident, explosion accident, etc. W belongs to the above conventional types, so the components of its emergency logistics system include seven components: "command layout", "policy supervision", "disposal and rehabilitation", "integration and coordination", "innovative development", "emergency plan", and "information sharing" [38]. Then, based on the idea of MD, the above components are modularly classified, among which the three components of "command layout", "disposal and rehabilitation", and "policy supervision" belong to the internally driven sufficient components (M); "information sharing" is an intermediate connective component (F); the two components of "innovative development" and "emergency planning" are externally guided components (G); and the component of "integration and coordination" belongs to the internally driven essential component (T). In OED, to realize the rapid integration of accident-type disaster emergency logistics system means to realize the rapid integration of the above four modules. Therefore, the levels of the above four modules are set as "worse", "poor", "standard", "good", and "excellent". The corresponding parameter values are 1 to 5. Due to time and economic costs, an orthogonal test table is designed in this paper. Taking the above modules as control features, the number of these cases is not determined subjectively, but calculated objectively according to the number of control features and the number of levels. After the number of control features is determined to be 4 and the number of levels to be 5, the experimental design scheme is directly determined as $L_{25}(5^4)$, the control characteristics of which must conform to the orthogonal table design criteria. These

25 cases have the characteristics of uniform dispersion and neat comparability, can meet the requirements of an orthogonal test table, and can represent 625 accident-type disasters in recent years. In this paper, the Delphi method is used to determine which 25 cases can meet the requirements of orthogonal test table design. These 25 cases should have the characteristics of large social influence, strong timeliness, diversified types, comprehensive coverage types, high academic value, relatively complete stages, and easy data collection and induction. The case source materials are usually official government information, mainstream news media reports, and published academic papers. It invites 20 experts and calculates the expert weights, "emergency rescue efficiency", "emergency rescue ability", and "emergency rescue effect", which are set as the response characteristics in the orthogonal test through the Delphi method. The 20 experts are in the fields of emergency logistics management, logistics information technology, and disaster information management and are divided into 5 groups according to educational background, practical ability, theoretical ability, and industry concern. By calculation, the calculated weights of the expert group are set as 0.2069, 0.2047, 0.2135, 0.1964, and 0.1785.

The levels of control characteristics are divided into 1, 2, 3, 4, and 5, corresponding to "worse", "poor", "standard", "good", and "excellent", respectively. In response characteristics, "emergency rescue efficiency" is the quantified ratio of emergency rescue time to the number of people affected by the disasters. If the time is more than 48 hours, it is set to 5, if it is within 12 hours, it is set to 1, and the other time corresponds to the intermediate value. Through calculation, the smaller the value, the higher the emergency rescue efficiency. "Emergency rescue capability" and "emergency rescue effect" are scored by the Delphi method, and then the weighted average is calculated. After scoring, the expert group finds that the larger the value of these two response characteristics, the stronger the emergency rescue ability and the better the emergency rescue effect. The orthogonal test data are shown in Table 1. As can be seen from Table 1, the response characteristic value needs to be normalized, that is, its SNR value is calculated, and range analysis is carried out according to equations (1) and (2) to reduce the absolute difference among the data. The influence trend of each control feature on each response feature is shown in Fig. 7. As can be seen from Fig. 7, the influence degree of each control feature on the emergency rescue efficiency is as follows: T>G>F>M, T has the greatest influence. The influence degree of each control feature on emergency rescue capability is as follows: G>T>M>F; G has the greatest influence. The influence degree of each control feature on the emergency rescue effect is as follows: M>T>G>F, M has the greatest influence.

In order to reduce the difference between the absolute values of the evaluated data, it is necessary to normalize the SNR. Since the calculation result

Table. 1. Data table for orthogonal test

Serial number	Control feature				Response feature		
	M	F	G	T	Emergency rescue efficiency	Emergency rescue capability	Emergency rescue effect
1	1	1	1	1	0.9600	1.5901	1.2047
2	1	2	2	2	0.7400	1.6251	1.3749
3	1	3	3	3	0.3000	2.8215	2.4011
4	1	4	4	4	0.2200	3.9917	2.965
5	1	5	5	5	0.2800	3.7581	3.7774
6	2	1	2	3	0.4800	1.8215	1.3832
7	2	2	3	4	0.4000	2.9895	2.8019
8	2	3	4	5	0.1800	5	4.0066
9	2	4	5	1	0.4000	2.4033	2.1964
10	2	5	1	2	0.5600	2.3832	1.9917
11	3	1	3	5	0.3600	3.8019	4.216
12	3	2	4	1	0.5000	3.1868	3.5796
13	3	3	5	2	0.3000	3.9672	3.9738
14	3	4	1	3	0.3600	3.0066	3.2152
15	3	5	2	4	0.3200	3.1763	3.6058
16	4	1	4	2	0.3800	3.5639	3.3928
17	4	2	5	3	0.3400	3.4466	3.9821
18	4	3	1	4	0.2800	4.1785	4.1851
19	4	4	2	5	0.2400	3.4204	3.9912
20	4	5	3	1	0.4400	2.8237	3.7752
21	5	1	5	4	0.2600	4	4.1956
22	5	2	1	5	0.3800	3.6058	4.2047
23	5	3	2	1	0.3600	2.6168	2.4182
24	5	4	3	2	0.3000	3.2226	3.7848
25	5	5	4	3	0.1800	4.7931	4.3854

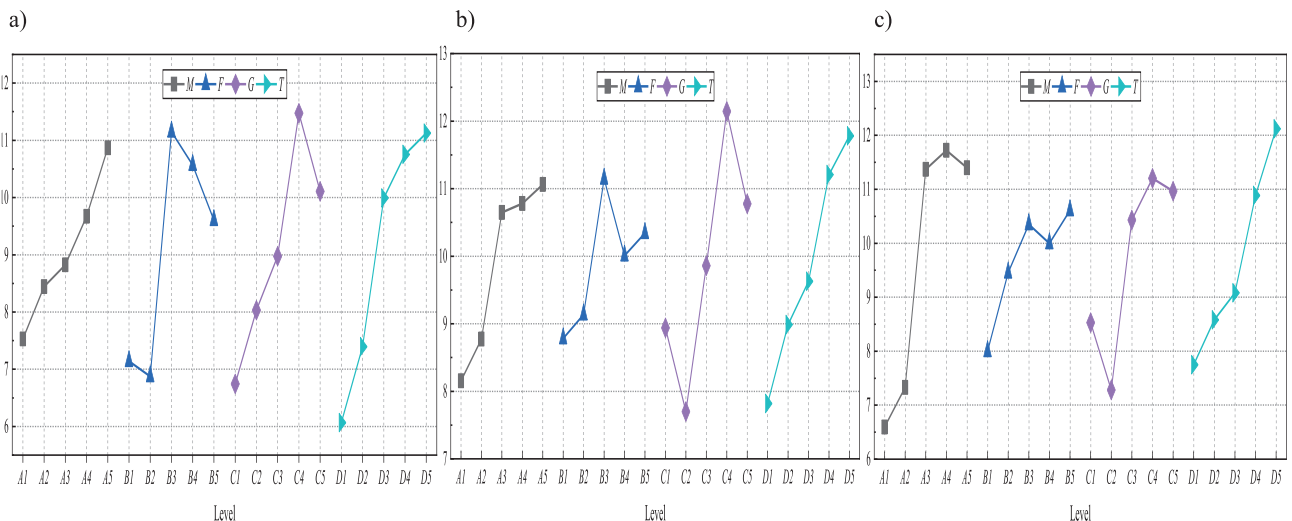

Fig. 7. Influence trend diagram: a) Emergency rescue efficiency, b) Emergency rescue capability, c) Emergency rescue effect.

of SNR usually adopts LTB type, the type of target is normalized. Based on the above formula, the numerical analysis method is adopted, and the Matlab computer software is used to convert the formula into code that can be recognized by the software. When the numerical value is input to the computer during the calculation, the relevant results will be obtained quickly. The calculation results of SNR, GRC, and GRG are shown in Table 2. In PCA analysis, the calculation results of eigenvalues, weights, and cumulative weights are shown in Table 3. The calculation results of the eigenvector and GRC contribution rate are shown in Table 4. The GRG mean values of each horizontal control feature are shown in Table 5. As can be seen from Tables 3, 4, and 5, the degree of influence of each control feature on GRG is ranked as follows: T>G>M>F.

The relationship between control features and their levels and the average GRG is shown in Fig. 8. As can be seen from Fig. 8, the multi-objective optimization scheme that affects the control features is $M_5F_3G_4T_5$. Among the above cases, no horizontal combination of the above optimal control features is found. Therefore, in order to verify the feasibility of the combination of control features obtained by multi-objective optimization, the historical case that conforms to the above multi-objective optimization scheme is selected from the conventional historical case base and regarded as the 26th case. The same method as the above 25 cases is used to determine the response characteristics, and the results are verified and compared with the previous results, as shown in Table 6. It can be seen from Table 6 that the control feature of the 26th group of cases is

Table 2. Calculation results of SNR, GRC, and GRG

Serial number	Emergency rescue effect			Emergency rescue efficiency			GRG (The weighted cumulative sum of GRC)
	Emergency rescue efficiency	Emergency rescue capability	Emergency rescue effect	Emergency rescue efficiency	Emergency rescue capability	Emergency rescue effect	
1	0.0000	0.0000	0.0000	0.3333	0.3333	0.3333	0.3333
2	0.1555	0.0190	0.1023	0.3719	0.3376	0.3577	0.3540
3	0.6948	0.5006	0.5338	0.6210	0.5003	0.5175	0.5371
4	0.8801	0.8034	0.6971	0.8066	0.7178	0.6227	0.7047
5	0.7361	0.7508	0.8845	0.6545	0.6674	0.8123	0.6779
6	0.4141	0.1186	0.1069	0.4604	0.3619	0.3589	0.3923
7	0.5230	0.5511	0.6533	0.5118	0.5269	0.5905	0.5292
8	1.0000	1.0000	0.9301	1.0000	1.0000	0.8773	0.9294
9	0.5230	0.3605	0.4648	0.5118	0.4388	0.4830	0.4699
10	0.3220	0.3532	0.3891	0.4244	0.4360	0.4501	0.4322
11	0.5859	0.7609	0.9695	0.5470	0.6765	0.9425	0.7137
12	0.3897	0.6068	0.8429	0.4503	0.5598	0.7609	0.5600
13	0.6948	0.7980	0.9237	0.6210	0.7123	0.8676	0.6955
14	0.5859	0.5560	0.7598	0.5470	0.5297	0.6755	0.5612
15	0.6563	0.6040	0.8485	0.5926	0.5580	0.7675	0.6070
16	0.5536	0.7045	0.8014	0.5283	0.6285	0.7157	0.6015
17	0.6201	0.6752	0.9253	0.5682	0.6062	0.8701	0.6388
18	0.7361	0.8433	0.9638	0.6545	0.7614	0.9325	0.7381
19	0.8281	0.6686	0.9271	0.7442	0.6014	0.8728	0.6946
20	0.4660	0.5013	0.8840	0.4836	0.5006	0.8117	0.5592
21	0.7803	0.8052	0.9658	0.6948	0.7197	0.9359	0.7360
22	0.5536	0.7147	0.9674	0.5283	0.6367	0.9388	0.6787
23	0.5859	0.4348	0.5393	0.5470	0.4694	0.5204	0.5021
24	0.6948	0.6166	0.8860	0.6210	0.5660	0.8143	0.6291
25	1.0000	0.9631	1.0000	1.0000	0.9313	1.0000	0.9739

Table 3. PCA analysis results.

Principal component	Eigenvalue	Weight	Cumulative weight
1	2.5363	84.54%	84.54%
2	0.4016	13.39%	97.93%
3	0.0621	2.07%	100%

Table 4. Calculation results of feature vectors and GRC contribution rate.

Response feature	Eigenvector	Contribution rate
Emergency rescue efficiency	0.5691	32.39%
Emergency rescue capability	0.6147	37.79%
Emergency rescue effect	0.5462	29.83%

the optimal level combination, that is, the level of the internally driven sufficient and necessary components is "excellent", the level of the intermediate connected components is "standard", and the level of the external guided components is "good". The response feature of "emergency rescue efficiency" is still determined by the quantified ratio of emergency rescue time to the number of victims as 0.1600, the "emergency rescue capability" is determined as 4.8215, and the "emergency rescue effect" as 4.8036 by the weighted average calculated after scoring by the expert group. By comparison, when the control feature is the optimal horizontal combination, the emergency rescue efficiency increases by 11.11%, the emergency rescue ability increases by 0.59%, and the emergency rescue effect increases by 9.54%. After

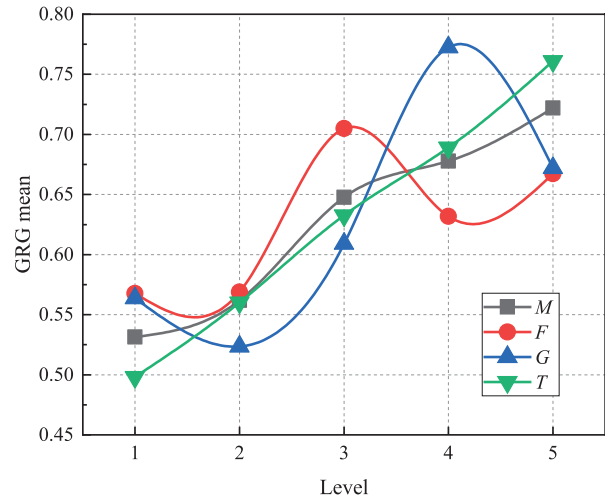

Fig. 8. The relationship between control features and their levels and the average GRG

optimization, the improvement of emergency rescue capability is small, but the efficiency and effect of emergency rescue are significantly improved, which verifies the feasibility of this method.

The results show that in the process of rapid integration of emergency logistics system for accident-type disasters, the emergency rescue work can be better implemented when the level of internal driving sufficient components and necessary components are "excellent", the level of intermediate connecting components is "standard", and the level of external guiding components is "good". The improved "CMO-Adaboost" method for the emergency logistics system rapid integration of accident type disaster can avoid the drawbacks of a single method and build a rapid integration framework including integration demands exploration stage,

Table 5. GRG mean values of each horizontal control feature.

Control feature	Level					Range
	1	2	3	4	5	
M	0.5315	0.5619	0.6476	0.6779	0.7220	0.1905
F	0.5677	0.5689	0.7050	0.6319	0.6674	0.1373
G	0.5637	0.5236	0.6091	0.7725	0.6720	0.2489
T	0.4982	0.5601	0.6326	0.6890	0.7609	0.2627

Table 6. Result verification table.

Serial number	Control feature				Response feature		
	M	F	G	T	Emergency rescue efficiency	Emergency rescue capability	Emergency rescue effect
25	5	5	4	3	0.1800	4.7931	4.3854
Optimal combination	5	3	4	5	0.1600	4.8215	4.8036
Increase rate					11.11%	0.59%	9.54%

components clustering stage, key integration direction judgment stage, and program intelligent learning stage. As an architectural component of the integration method, it realizes the method design of combining weak classifiers into strong classifiers, integrates advantages, compensates for shortcomings, shortens the overall integration time of the system, completes adaptive boosting, and realizes intelligent learning for the rapid integration of the emergency logistics system of accident-type disasters and promotes green sustainable development.

Conclusions

The above optimal control feature combination obtained by the "CMO-Adaboost" method can directly determine the importance of the internal driving, external guiding, and intermediate connecting components modules at the macro level and provide theoretical suggestions for government management departments to deal with accident-type disasters in a short period of time to improve the efficiency of emergency rescue. In the face of new cases, government management departments need to focus on the rapid integration of four types of internally driven components, namely "command layout", "policy supervision", "disposal and rehabilitation", and "integration and coordination". Secondly, attention needs to fall on the two types of externally guided components, namely "innovative development" and "emergency plan". The work involved in the intermediate connection component of "information sharing" can be carried out appropriately. With the passage of time and the development of society, more new cases will lead to the existing case data composition, the system components screening results, and the optimal control feature combination can not fully adapt to the new environment and new problems. The concept of green sustainable development requires society to see not only the present, but also the future. Therefore, in the future, it is still necessary to refine the attribute characteristics of the cases according to the actual situation and the needs of government management departments and regularly update the cases in the orthogonal table. The corresponding component identification and optimal control feature combination will change accordingly. However, the concept and purpose of the "CMO-Adaboost" method will remain unchanged, and it is universally applicable to new accident-type disaster cases. It also has reference value for other types of emergencies. The updating of case data under a new environment, new problems, and identification of updated components and modules will be the key points of this method in the future, and the new optimal control feature combination generated by it will continue to provide theoretical suggestions for government management departments to deal with accident-type disasters and promote green sustainable development.

Acknowledgments

The author wish to thank supporting project which number is "2022JH4/1010008" and supported by 2022 Liaoning science public welfare research fund (Soft Science Research Program), in addition to the project which number is "2025lslqnwzzkt-065" and supported by 2025 Liaoning economic and social development research.

Conflict of Interest

The authors declare that they have no conflicts of interest.

References

- HONG J., WANG L., GU J., LI Y. Green recovery in the wake of public health emergencies: policy instruments and their effects in china. *Journal of environmental management*, **354**, 120408, **2024**.
- ALIZADEH M., KALANTARI K.A.A.R., JAHANI H., MAKUI A. Prevention of post-pandemic crises: a green sustainable and reliable healthcare supply chain network design for emergency medical products. *Journal of Cleaner Production*, **434**, 139702, **2024**.
- WU C. Research on basic theory of safety complexity science: laying a foundation for new highland of safety science. *China Safety Science Journal*, **31** (5), 7, **2021**.
- WEI Y., NI J., HUANG D. Accelerate the construction of a government-led emergency logistics system. *Emergency Rescue in China*, **2**, 36, **2021**.
- XU G., LI H., TIAN Y. Organization improvisation inducing mechanism: based on stage creative process. *Journal of Management Science*, **33** (5), 116, **2020**.
- LIU X., MENG H., AN X., XING J. Integration of functional resonance analysis method and reinforcement learning for updating and optimizing emergency procedures in variable environments. *Reliability Engineering and System Safety*, **241**, 109655, **2024**.
- SUN Z., WANG Q., CHEN L., HU C. Unmanned technology-based civil-military intelligent logistics system: from construction to integration. *Journal of Beijing Institute of Technology*, **31** (2), 140, **2022**.
- ILONA J.G., NADIIA S., NATALIIA G., MARIUSZ S. Sustainable development of intermodal freight transportation – through the integration of logistics flows in ukraine and poland. *Sustainability*, **16** (1), 267, **2023**.
- WANG Z., JIA H. An intuitionistic fuzzy grey-markov method with application to demand forecasting for emergency supplies during major epidemics. *Grey Systems: Theory and Application*, **14** (1), 185, **2024**.
- LI J., ZHAO L. Emergency resource layout planning methodology with multiple constraints. *Applied Mathematics and Nonlinear Sciences*, **9** (1), 91B32, **2024**.
- SUN Z., WANG Q., CHEN L., HU C. Unmanned technology-based civil-military intelligent logistics system: from construction to integration. *Journal of Beijing Institute of Technology*, **31** (2), 140, **2022**.
- SALMASNIA A., KIAPASHA Z. Integration of sub-task scheduling and logistics in cloud manufacturing

- systems under setup time and different task arrival times. *International Journal of Computer Integrated Manufacturing*, **36** (7), 985, **2023**.
13. WU X., YANG M., WU C., LIANG L. How to avoid source disruption of emergency supplies in emergency supply chains: a subsidy perspective. *International Journal of Disaster Risk Reduction*, **102**, 104303, **2024**.
 14. WANG Y., LYU M., SUN B. Emergency resource allocation considering the heterogeneity of affected areas during the covid-19 pandemic in china. *Humanities and Social Sciences Communications*, **11** (1), 225, **2024**.
 15. MOHAMMED T.M., DALYA E., ARIEL H.S., ISMAEL S.E.S., NI'MA S.A., HEMANT S., LEONARD M., HAMID J. Effective partnership and in-country resource mobilization in sudan for cvdvp2 outbreak response amid multiple emergencies in 2020-2021. *BMC Public Health*, **24** (1), 235, **2024**.
 16. HAN Y., HAN X. Research on the implementation mechanism of rapid construction of prefabricated emergency hospital from the perspective of industry chain integration – based on the caseanalysis of wuhan huoshenshan hospital. *Industrial Engineering and Management*, **26** (6), 195, **2021**.
 17. WU H. Integration of government agencies and social resources: an optimized path of emergency management from the perspective of metagovernance. *Journal of Graduate School of Chinese Academy of Social Sciences*, **42** (3), 116, **2022**.
 18. LI R., TANG Y. Digital twins traction process integration of emergency management: an ongoing exploration. *China Public Administration*, **10**, 30, **2022**.
 19. HE X., KONG Z., LIU X. Selection of emergency resource mobilization cooperation mode based on binary semantic grp method. *Transactions of Beijing Institute of Technology*, **43** (2), 178, **2023**.
 20. WEN Z., LI Y. From “plate integration” to “organic integration” : a study on the optimization path of emergency management system with chinese characteristics. *China Public Administration*, **5**, 155, **2022**.
 21. YUAN Y., FAN B. Research on emergency resource lay out from the perspective of big data driving. *Journal Center of School of Information Management*, **12** (3), 35, **2022**.
 22. ZHAO F., WANG X., LIU B., SUN W., LIU Z. Research on optimization of medical waste emergency disposal transportation network for public health emergencies in the context of intelligent transportation. *Applied Sciences*, **13** (18), 10122, **2023**.
 23. HU Y., WAN Y., LI Z., QI Z. Research on gas emergency assistance decision-making by integrating knowledge graph and case-based reasoning. *Fire Science and Technology*, **43** (2), 143, **2024**.
 24. LI X., JIANG M., YANG X., GU D., SONG L. Collaborative relationship and evolution features among emergency decision-makers in grave public health emergencies. *Information Science*, **41** (5), 10, **2023**.
 25. HU D., FENG J., YANG Y., YI G. Generation of emergency response plan for benzene explosion considering the disposal effect. *Journal of Zhejiang University (Science Edition)*, **49** (4), 457, **2022**.
 26. ZHAO K., ZHANG X., LI C., ZHAO C., GAI Y. Case knowledge reuse method of railway train control system emergency plan. *China Safety Science Journal*, **32** (S2), 217, **2022**.
 27. LUO Z., PAN J. Review of current situation and development trend of emergency materials demand forecasting. *Science Technology and Engineering*, **23** (18), 7622, **2023**.
 28. FU Z., WANG Z., DENG Y. Modular design and application study of earthquake rescue demolition technology training platform. *Fire Science and Technology*, **43** (1), 91, **2024**.
 29. HENNINGSSON S., EATON B.D. Governmental regulation and digital infrastructure innovation: the mediating role of modular architecture. *Journal of Information Technology*, **38** (2), 126, **2023**.
 30. CHEN Y., LIU X. Personnel Emergency Evacuation Simulation Modeling of Cultural Relic Scenic Spots Based on Social Force Model. *Safety and Environmental Engineering*, **30** (4), 100, **2023**.
 31. GUO Y., CHEN H., SI Q., BAI X., WANG P., YUAN S. Optimal design of high-pressure emergency water pump based on orthogonal test. *Journal of Grainage and Irrigation Machinery Engineering*, **41** (6), 630, **2023**.
 32. WANG H., WANG W., HOU H., DENG P., JIANG Q. Improved ga-bp based early warning of warehousing and logistics risk in cruise ship construction. *Navigation of China*, **45** (3), 57, **2022**.
 33. WANG H. Construction of operational system of emergency supply chain in china based on scor. *Statistics of Inner Mongolia*, **2**, 27, **2021**.
 34. HUANG H., ZHANG L., YAO L. Multi-objective optimization of injection molding process based on grey relational analysis. *Plastics Science and Technology*, **47** (1), 104, **2019**.
 35. ZHANG T., ZHAO Y., YU T., YU T., SHI J., ZHAO J. Study on polishing slurry waste reduction in polishing monocrystalline silicon based on ultrasonic atomization. *Journal of Cleaner Production*, **233**, 1, **2019**.
 36. NGOC M.T., PETRA B., MARIA O., WOLFGANG K.H. Principal component analysis in an asymmetric norm. *Journal of Multivariate Analysis*, **171**, 1, **2018**.
 37. TAO X., CHANG R., LI C., WANG R., LIU R. Density-sensitive robust fuzzy kernel principal component analysis technique. *Neurocomputing*, **329**, 210, **2018**.
 38. MA W., WEN X., XU J. A study on regional emergency logistics system elements identification and inter-element interaction model for accident-type disasters. *Management Review*, **35** (6), 311, **2023**.